

# MorseMonkey

## Introduction

Thank you for your purchase of the MorseMonkey.

The device is intended to give you a simple tool to practice Morse Code using a straight keyer or an Iambic keyer. The primary ways to practice are:

- Tap the letter or number that is displayed for you and it will display if it was correct (Dictation)
- Tap random letters or numbers and it will display them if it can understand them (Practice)
- Repeat the letter or number you hear and it will display if it was correct (Echo)
- Listen to random call signs and confirm you understood them

It uses digital logic that is powered by 3 volts, so it can run on two AA batteries (not included). Alkaline batteries are recommended.

Do NOT attempt to supply it from a 5V power source, as the LCD display and PIC microcontroller are rated for 3.3V typical operation. (The PIC microcontroller has a max rating of 4V, the LCD has a max rating for 3.6V).

Items which are not supplied, but will be needed for use:

- To listen to the audio generator, you will have to supply a small speaker or earbud to plug into the audio jack. The volume control can be used to reduce the output, which can be very loud when using earbuds.
- Your own keyer and a 3.5mm phone jack. The unit can use an Iambic keyer (default) or be set to use a straight keyer. A menu setting controls which type of keying the unit is expecting.

This is a single board you can place on any nonconductive surface when in use. Or you can fabricate your own case for it.

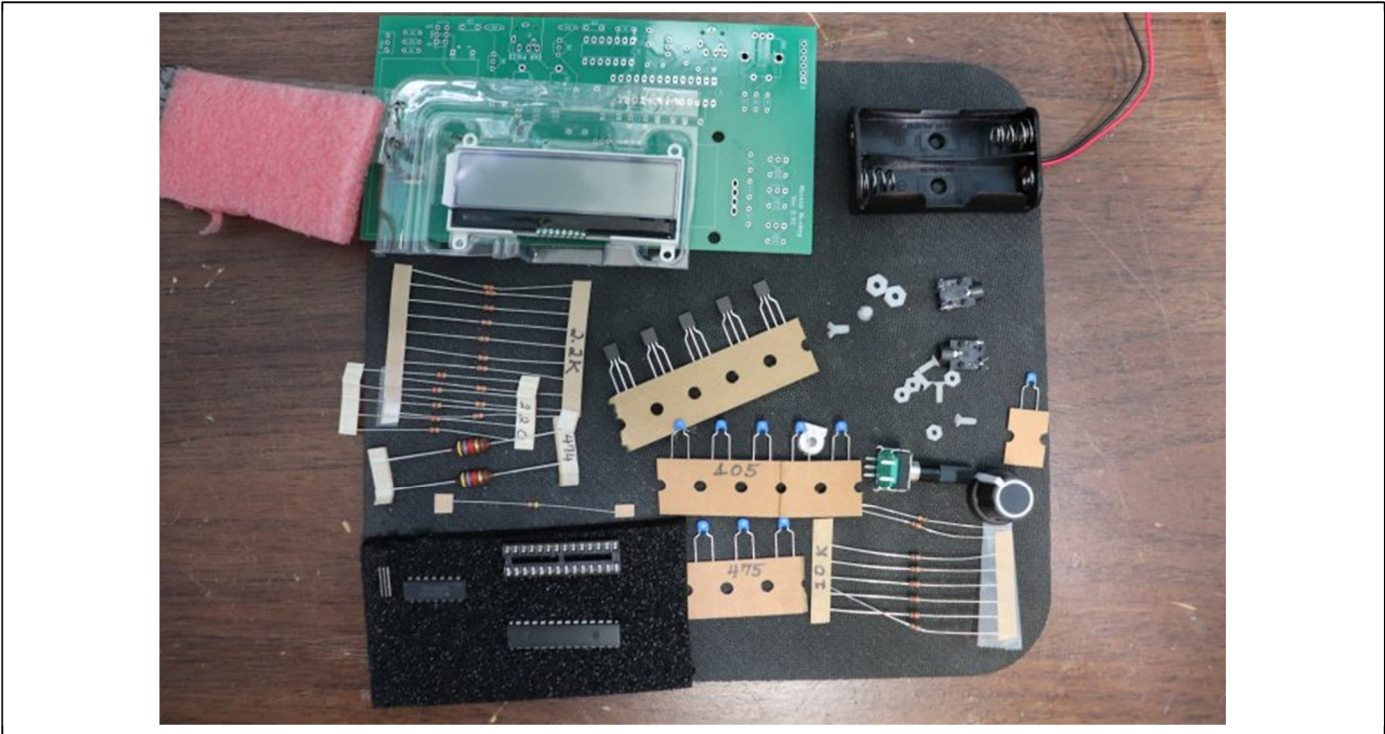

### Assembly Instructions

Insure all the parts are present. We hand pack the parts, and try to insure that everything is included. If anything is missing, please contact us.

### Parts List

Ref	Description	Value	Quantity
BT1	Battery Holder		1
C2, C5, C6, C7, C8	Capacitor marked 105	1.0uf	5
C3, C4, C9	Capacitor marked 475	4.7uf	3
C1	Capacitor marked 474	0.47uf	1
R4, R8, R9, R10, R11, R12, R13, R19	Resistor coded brown – black – orange	10K	8
R1	Resistor coded yellow – violet -red	4.7K	1
R7, R16, R17, R18, R24	Resistor coded red – red -red	2.2K	5
R2, R3, R6, R6, R14, R15,R20, R21, R22, R23	Resistor coded red – red -brown	220	10
RV1	10K potentiometer	10K	1
SW1	Rotary encoder		1
SW2	Power switch		1
J1, J2	3.5mm Audio Jack		2
L1, L2	Inductor marked yellow – violet - red	4.7mH	2
U2	Preprogrammed MCU	PIC 24HJ64GP202	1
U1	Shcmitt trigger inverter	74(A)HC14	1

U3	LCD Display	NHD-C0200	1
Q1	MOSFET transistor	2N7000	1
Q2, Q3, Q4, Q5, Q6	NPN Transistor	2N3904	5
--	28 pin DIP socket		1
--	Knob		1
--	Circuit Board		1
--	Nylon screws 2-56		4
--	Nylon nuts 2-56		4
--	Nylon screws 4-40		2
--	Nylon nuts 4-40		2

Tools Required:

- Soldering iron with small tip
- Solder 0.082 inch or 0.81mm diameter is preferred
- Diagonal cutters to trim leads
- Small screwdriver and needle nose pliers to tighten the nylon screws which hold the display and battery
- Digital multimeter to check polarity and troubleshoot if necessary
- Solder wick or other desoldering tool in the event a part needs to be removed
- Small quantity of glue (Elmers© glue all or similar)
- Mouse pad to place the board on to hold it steady while soldering

1. Start by inserting all lowest profile parts first. These would be the resistors. From the left to the right side, 10K resistors are located at R9, R10, R11, R8, R12, R13, R4, R19.

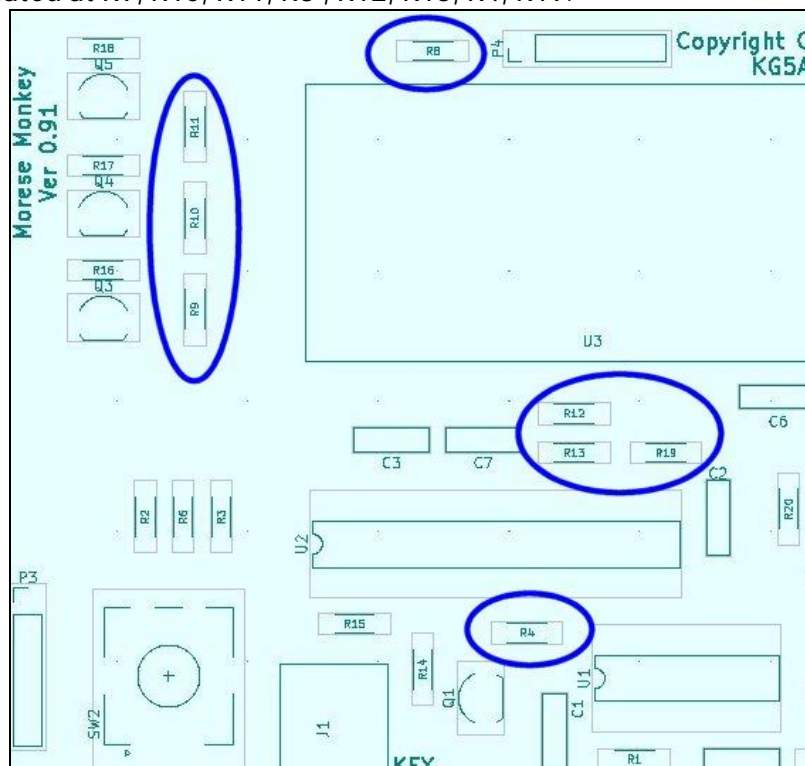

2. Next are 2.2K resistors located at R16, R17, R18, on the upper left, and R7, R24 on the lower right.

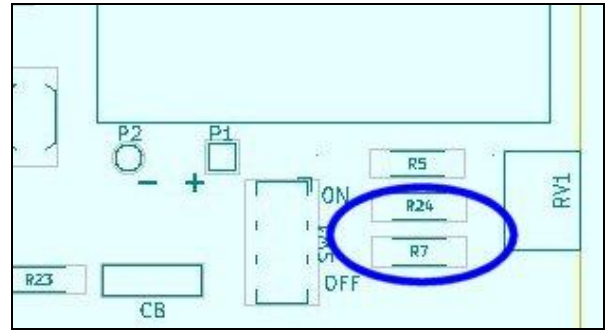
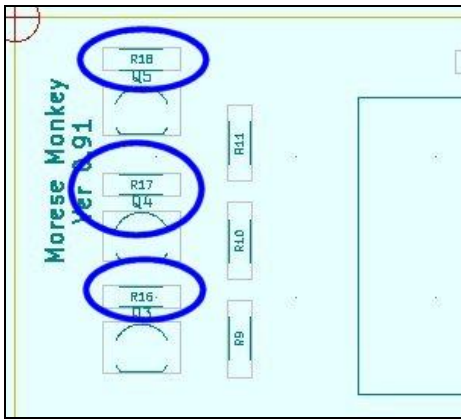

3. Next are 220 ohm resistors located at R2, R6, R3, R15, R14, R20, R21, R22, R23, R5.

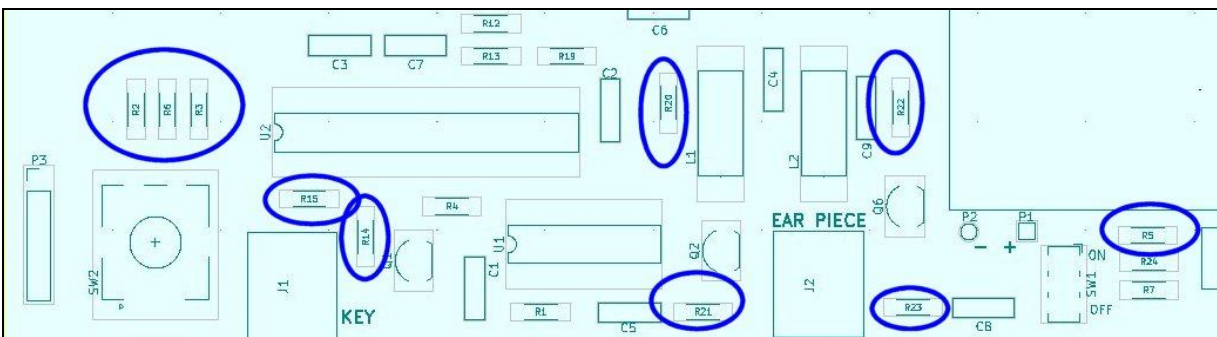

4. Last is 1.8K located at R1.

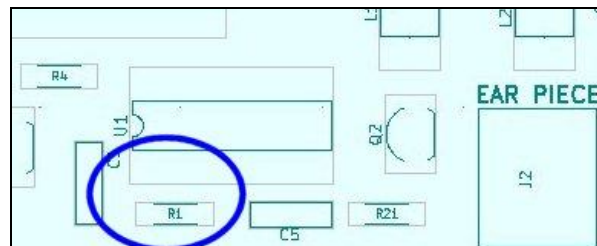

5. Next install the potentiometer RV1, located at the lower right. It is designed to hang slightly off the board to allow easy adjustment with a finger.

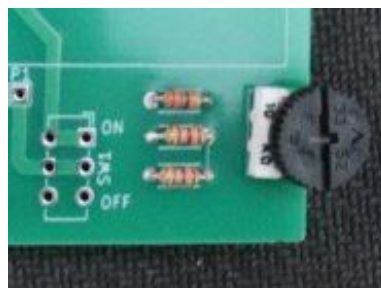

6. Turn the board over and carefully solder each lead, insuring not to short out to any adjacent traces on the circuit board.

- The next lowest profile parts is the **socket** for the micro controller U2, and the inverter U1 which is a basic oscillator for producing the audio tone, and U3 the LCD display. Do not insert the microcontroller yet. The LCD display has 4 holes for the nylon screws. Install the 2-56 screws through the holes on the display, and the nuts on the underside of the board. After attaching the nut, a small drop of glue can be used to hold the nut in place.

The easiest way to attach the nylon screws it to hold the nut on the back of the board flat with a thumb or finger, and screw in the screw from the top side. The helps keep the nut flat the threads easily. **Do not over tighten.** The nylon is soft and can strip easily. Instead, use a small drop of glue to hold the nut in place.

- To hold the socket and 74HC14 place, you can slightly bend two of the legs outward from the bottom, so it will not fall out when trying to solder it.

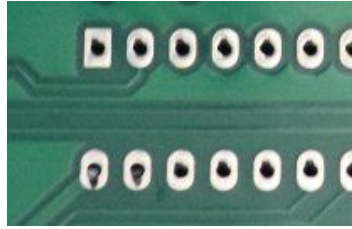

- Again, turn the board over and solder the components in place. After soldering there is no need to trim the leads.

The next parts to install are the capacitors. Capacitors are marked in numbers like resistors are marked in colors, although the text is very small. The code 105 means "one", "zero", followed by 5 more zeros, which means 1,000,000 picofarads, which is 1 microfarad. All capacitors are non-polarized.

- Again, from the left to right, beginning below the LCD display, insert the 1.0uF capacitors C7, C2, C6, C5, C8 in their locations, and solder them in place and trim the leads.

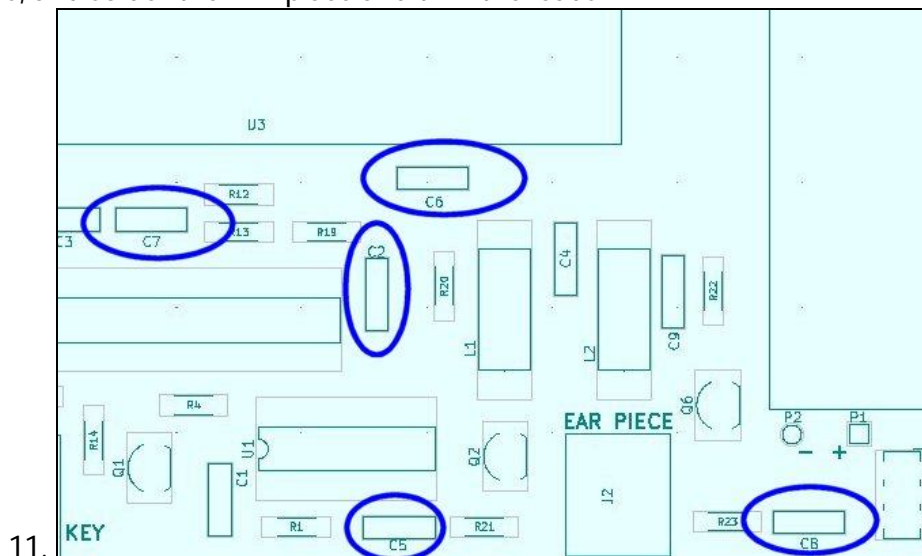

- Next install capacitors 4.7uF C3 below the LCD, C4 , C9 which are in the lower right and solder them in place and trim the leads.

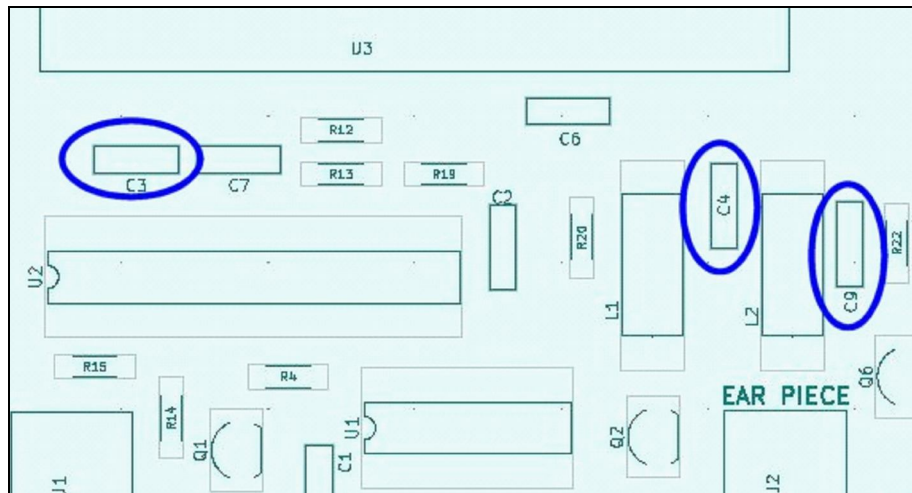

13. Last, install C1 located on the bottom next to U1 and solder it in place and trim the leads.

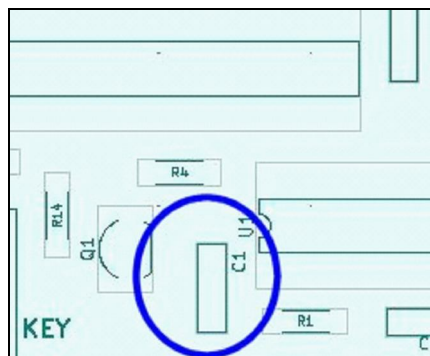

14. Next install the audio jacks. J1 is used to attach the keyer. J2 is for the ear piece if used. Solder the jacks in place.

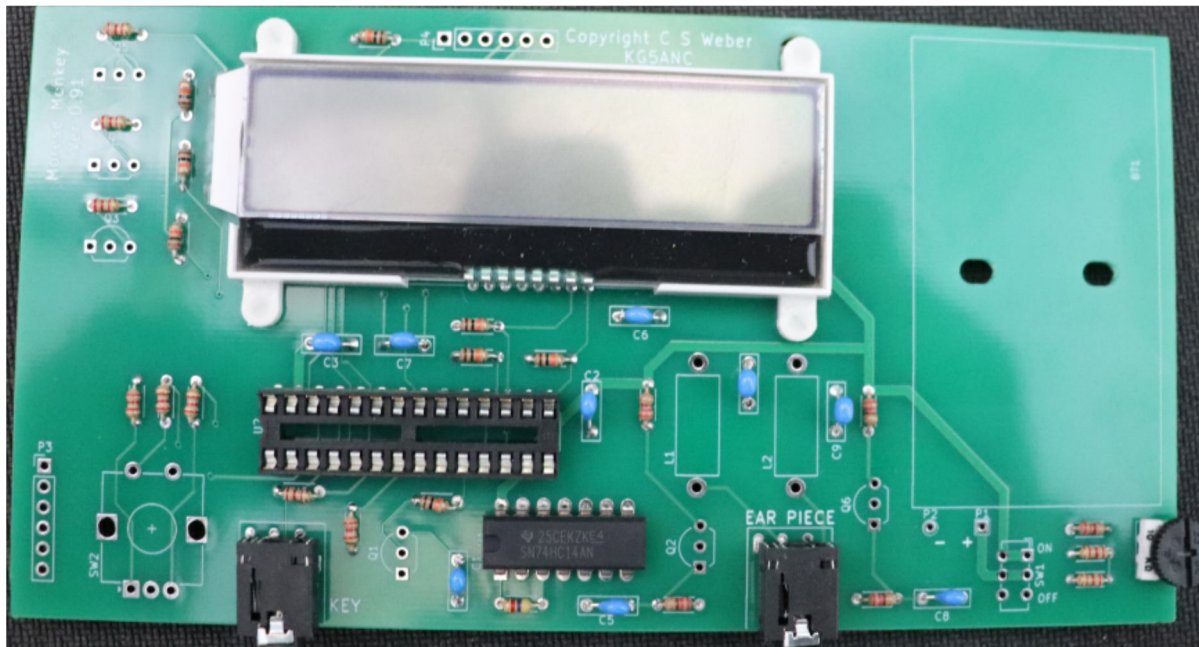

15. Next install the inductors, L1 and L2. Solder the inductors in place, and trim the leads.

16. Next, install the power switch SW2, the direction is not important. Solder the switch in place.

17. Next install the transistors Q1 through Q6. Install the transistor with the flat face matching the outline on the circuit board.

Q1 is delivered on the foam to protect it from static. It is installed to the left of U1. Do not get the Q1 confused with the other transistors.

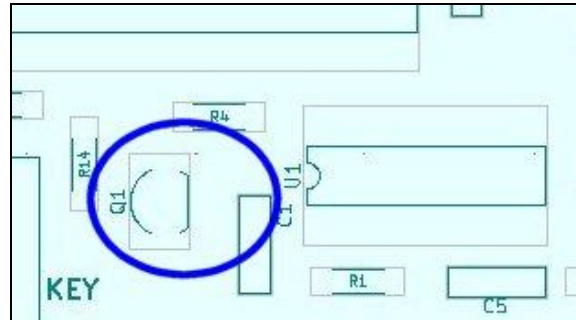

Q2 and Q6 are on either side of the earpiece jack.



Q3, Q4, and Q5 which are located in the upper left next to the LCD display. Solder the transistors in place. And trim the leads.

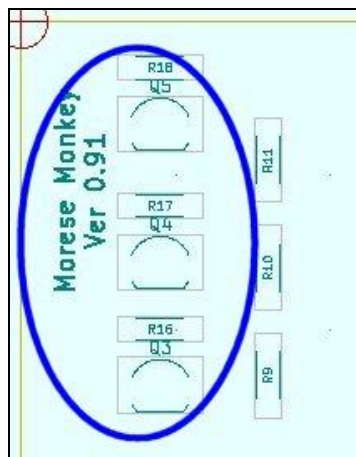

18. The battery holder can be attached next. Use the 4-40 screws to attach the battery holder to the boards, and insert the red wire (+) into the hole marked P1 below the holder. Insert the black wire (-) in to the hole marked P2.

The nuts for the battery holder are best threaded by placing the rounded (non-hex) side first. This image shows the rounded side toward the head of the nut. Hold the nut on the back of the board similar to the description for installing the screws on the LCD.



All the nylon screws can be held in place with a small drop of glue on the nut side.

19. Last install the SW1 rotary switch, and solder in place. Then attach the knob by aligning the notch flat side and pressing it on the shaft.

There is a protective film over the LCD display which can be peeled off.

20. Before installing the 28 pin microcontroller, you should use your DVM to test the voltage on the 28 pin socket pins, to insure the voltage is the correct polarity. The pins are numbered below:

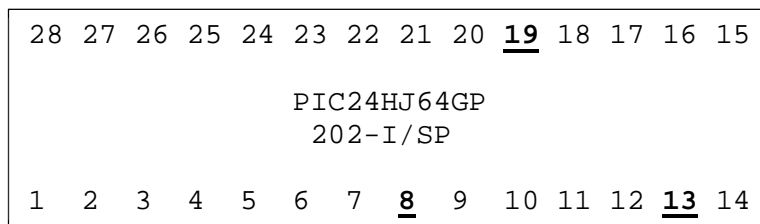

Pins 8 and 19 are ground or negative. Pin 13 is the positive supply. Also pin 27 will be ground, and pin 28 will be the positive supply.

Install the batteries and turn on the power switch. Measure the voltage from pins 19 or 8 to pin 13 to confirm about 3 volts.

P4 and P3 are not used at this time, however may be used in the future. P3 is a serial output which can be used for debugging or reloading firmware. P4 is for a PICKIT connection to program or reprogram the device.

21. Insuring the notched end on the MCU chip is to the left (placing pin 1 nearest to the rotary dial) plug the PIC 24HJ64GP202 into the 28 pin socket and turn the power on. The display should show "MorseMonkey" and version number for about ½ a second.



- a) If the LCD does not display anything, turn the unit off and inspect all the connections.
- b) Insure the U2 is plugged in correctly, and all solder connections are clean.
- c) Insure the batteries are in correctly, and measure the voltages on the MCU (U2), and U1 pin 14 which should be +3, U1 pin 7 which is ground.



## Wiring a Keyer

The user will have to supply a keyer with a 3.5mm phone jack, and optional earbud to listen to the tones.



To connect an lambic keyer, the contacts are connected to the tip and the ring of the phone plug and the common ground is connected to the sleeve. The user can set which of the contacts (tip or ring) will produce the dah or long, and the other contact will produce the dit or short.

To connect a straight keyer, simply connect the keyer to either the tip or ring, and the sleeve as ground. The straight key contact is set the same as the lambic *long* contact, as described in the settings section below.

You select which type of keyer you are using through a menu selection described in the setting section below.

Ensure the speaker or headphone jack is plugged all the way in. **The audio output can be very loud.** Turn the volume control VR1 almost all the way counter clockwise (volume down), then turn it up to a comfortable level.

## Using the MorseMonkey

The MorseMonkey menu is shown in the display. Rotating the dial will select the menu options, and pressing the knob will select that menu option.

The menu, which is referred to as the “top” menu, will cycle through the following:

Settings – Practice – Dictate – Echo – Copy

Selecting “Settings” will allow the user to select various settings. Setting are restired from what was saved when you turn the unit on.

Selecting “Practice” will display “Press to Start...”. Or you can turn the knob to “Back” and press the dial to return to the top menu.

Selecting “Dictation” will display “Press to Start...”. Or you can turn the knob to “Back” and press the dial to return to the top menu.

Selecting "Echo" will display "Press to Start". Or you can turn the knob to "Back" and press the dial to return to the top menu.

Selecting "Copy" will display "Press to Start". Or you can turn the knob to "Back" and press the dial to return to the top menu.

## Settings

Settings will allow you to select the type of keyer, enable the light, set the WPM, enable playback, and select the contact for the keyer. To change a setting, turn the dial to the desired setting on the top line, and press the dial until the desired setting appears on the lower line.

The settings options are:

- Keyer can be either Iambic or straight.
- Lights can be either on or off. When using a mode that provides a scored result, the light provides a green or red feedback to the user.
- WPM can be 5, 10, or 18. In some operations, it controls the expected duration of dits and dahs. In other operations, it only controls the time between each character (Farnsworth timing).
- Sidetone can be either on or off. This will playback what you are keying, allowing you to hear the keying.
- Straight/Iambic DAH sets the Keyer Jack J1 contact which will be used for the Straight key or for the long DAH in an Iambic key. This can be either the tip or the ring contact. How to wire a keyer is discussed in the section "Wiring a Keyer"
- Save will store the settings back into flash memory. To protect writing to the flash memory excessively and wearing it out, it will only save the settings if they are changed.

When the unit is powered up, the settings that were last saved are restored.

Turn the dial to "Back" and press it to return to the top menu.

The operation of the remaining functions is described next.

## Practice

Practice will let you tap any characters you wish, and display them. There is no scoring of the characters. In Iambic mode the left and right paddles are used for dit and dah. In straight keying, the amount of time you spend to tap the let depends on the WPM setting. It will also display a series of . and - to show the interpreted dits and dahs. The duration of a dit and a dah is loosely determined by the WPM setting.

When you are done, simply press the dial and the display will return to the top menu.

## Dictate

Dictate will display a letter and expect you to tap it on the keyer. In Iambic mode the left and right paddles are used for dit and dah. In straight keying, the amount of time you spend to tap the let depends on the WPM setting. If the unit thinks you keyed the letter correctly, it will display "Correct" and will change the display

light to green briefly if the light is enabled in the settings. If the unit thinks you keyed the letter incorrectly, it will display "Incorrect" and the display light will change to red briefly if the light is enabled in the settings.

When you are done, simply press the dial and the display will show a summary of the correct and incorrect characters. Press the dial again to return to the top menu.

## Echo

Echo will produce beeps which represent characters. When you hear the character, you must type it back. If you do not start any keying within 10 seconds it will repeat the character. In lambic mode the left and right paddles are used for dit and dah. In straight keying, the amount of time you spend to tap the let depends on the WPM setting. If the unit thinks you keyed the letter correctly, it will display "Correct" and will change the display light to green briefly if the light is enabled in the settings. If the unit thinks you keyed the letter incorrectly, it will display "Incorrect" and the display light will change to red briefly if the light is enabled in the settings.

The unit will also display the actual character that was played.

When you are done, simply press the dial and the display will show a summary of the correct and incorrect characters. Press the dial again to return to the top menu.

## Copy

This operation does not expect the user to key anything. Copy will generate a random callsign and play it back. The goal is to train the users to listen to the code and correctly copy it down. The callsign is 6 characters in a 2X3 form:

- Begins with either a K or W
- A random letter
- A random number
- Three random letters.

The duration of each dit and a dah are not controlled by the WPM, only the pause between each character. This encourages the user to hear the whole "character" rather than a string of longs and shorts. The callsign will repeat every 10 seconds until you stop it.

You do NOT tap the callsign back. Instead, when you are confident of the callsign, press the keyer once (the dah or long when using an lambic keyer) and the display will show you the generated callsign. Then press the keyer again, and another random callsign will be created and played.

When you are done, simply press the dial and the display will return to the top menu.



## Circuit Operation

The core of the operation is the PIC24HJ64GO202 MCU. The MCU runs a 50Mhz instruction clock.

The dial generates a quadrature signal based on the rotation direction. The common contact is tied to ground, and the microcontroller uses internal pullup resistors on the two contacts. The MCU is interrupted when signal A on RA4 changes. After a short period (about 2 ms) it tests to determine if the signal is still low, and whether signal B is high or low. This determines the direction of rotation.

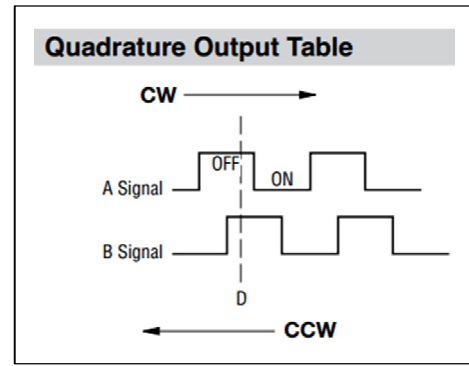

The button press operation interrupts the MCU in a similar manner on RA0.

The key plug tip input is connected to RB2 and the key jack ring is connected to RB3. These interrupt the MCU in a similar manner. When a press is detected, the firmware decides if it was a long or short based on the configuration setting.

The 220K resistors at the inputs to the dial or keyer are user to slow any "outflow" current from the MOSFETS from exceeding their max rating, this is additional protection that is optional.

The display is driven by a serial peripheral interface (SPI bus) which sends serial commands to the LCD display using RB8 and RB9. Resistor R12 and R13 are simple pull-up resistors to insure a voltage is present when no data is being transmitted.

The display contains three LEDs to illuminate the background: Red, Green, Blue with a common anode (+). They are controlled by Q4, Q3, and Q2 respectively. The transistors are driven by MCU outputs RB10, RB11, and RB12. When the outputs are low, the transistor base is basically at ground, and the transistor is cut off. When the output become high, the current is allowed to flow from ground on the emitter to the collector, and the transistor is in Vce saturation mode, with a typical voltage drop of 0.2V. The LEDs are then powered through current limiting resistors R16, R17, R18 from up to the positive supply.

The Schmidt trigger inverted U2A is used to create an approximate 1Khz oscillator. A Schmidt logic device will cleanly change from one state to another when the input voltage reaches a specified point. It will reverse when the input voltage falls below another specified point. This means any voltage between those points will not generate noise, and the level when the change occurs is predictable. The difference is typically 0.9 volts. Starting with an output of high, the input level charges through R1 and C1. When the input reaches a specified voltage,

the output will invert. This will cause the capacitor to now discharge through R1 until the input falls to the other specified level. The MOSFET Q1 is used to short out the C1 which turns off the oscillator.

The output from the U2A oscillator is buffered with U2B, and drives transistors Q2 and Q5 as class A amplifiers. VR1 is used to control the signal level into the transistors. C4 and L1, or C9 and L2 form a simple band pass filter to round off some of the square wave and block DC current from the earpiece.

Switch S2 turns the unit on or off.

## **Additional Information**

Detailed instructions and any new firmware can be found here:

<https://www.unforsceneproductions.com/MorseMonkey/morsemonkey-info.html>